



IMPACT SERIES

IP66 Industrial Range RCD Protected Outlets



Data Specification **2024**



AUSTRALIA WIDE DELIVERY
Expedited delivery to all states in Australia



SAME DAY DISPATCH
Orders prior to 12PM will be dispatched the same day



5 YEAR WARRANTY
You can get a trusted 5 Year In House Warranty with CSG

[DESCRIPTION]

To help avoid electrocution between the body and the earth in industrial environments the IMPACT RP Series range of combination switched socket outlets have inbuilt RCD protection. The RCD works by constantly monitoring comparing the current flow in both the Active and Neutral circuits of an electrical installation, and if an imbalance of more than 30mA is detected, the RCD cuts electrical supply to the appliance. The IMPACT range of IP66 rated combination switched sockets outlets are designed for tough Australian conditions. Lockable and manufactured from impact resistant material ensures it will withstand harsh treatment in most industrial environments.

[FEATURES]

- Fitted with Electromagnetic 10Ka RCD
- Impact Resistant
- Automatic Snap Catch Latch
- Silicone Based Seals
- Hose Proof & Dust Resistant Flaps
- Lockable RCD cover
- Screw Caps included

[TECHNICAL PARAMETERS]

- IP Protection: IP66
- Rated Voltage: 250V/500V AC
- Rated Frequency: 50/60Hz
- Operating Temp: -40°C - 80°C
- Complies with:
AS/NZS 3100:2017+A1
AS/NZS 3112:2017
AS/NZS 61008.1:2015

[APPROVALS]

SAA Approved

[IMAGES]



RPCS520



RPSO510

[SPECIFICATIONS]

Product Code	Rating (Amps)	Voltage (V)	No. Of Pins	Configuration	Conduit Entries
RPCS310	10A	250V	3	Flat Pin	2 x 25mm, 2 x 32mm
RPCS315	15A	250V	3	Flat Pin	2 x 25mm, 2 x 32mm
RPCS410	10A	500V	4	Round Pin	4 x 25mm
RPCS420	20A	500V	4	Round Pin	4 x 25mm
RPCS432	32A	500V	4	Round Pin	4 x 25mm
RPCS510	10A	500V	5	Round Pin	2 x 25mm, 2 x 32mm
RPCS520	20A	500V	5	Round Pin	4 x 25mm
RPCS532	32A	500V	5	Round Pin	2 x 25mm, 2 x 32mm
RPSO310	10A	500V	3	Round Pin	4 x 25mm
RPSO315	15A	250V	3	Flat Pin	4 x 25mm
RPSO510	10A	250V	5	Flat Pin	4 x 25mm
RPSO520	20A	500V	5	Round Pin	4 x 25mm
RPSO532	32A	500V	5	Round Pin	4 x 25mm

[WIRING DIAGRAM]

3 Phase Connection - Without Neutral

NOTE: RCD's will function even without a neutral supply or load. However, when installing an RCD to a circuit without the supply of a neutral connection, for the test button to operate correctly, the connection of a bridging resistor (R2.4W not supplied) between the load side neutral terminal and load side phase terminal 2 or 4 is required. Failure to include a bridging resistor in these installations may result in damage to the test circuit.

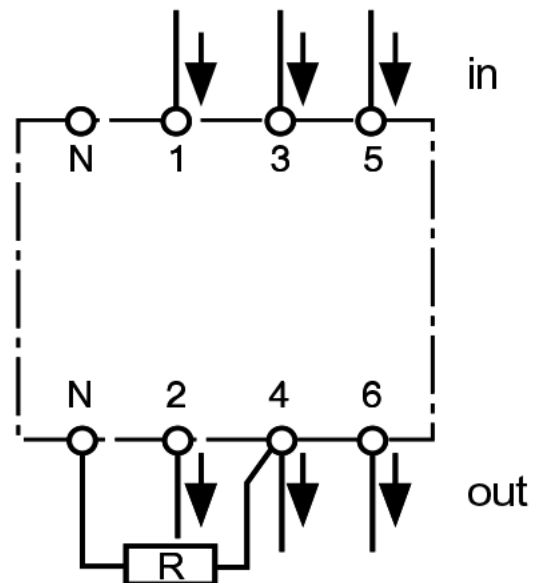

[WARRANTY]

Connected Switchgear IMPACT series of product come with a trusted 5 Year In House Warranty. That means that you have peace of mind knowing that if a fault develops within a five year period, Connected Group Australia will cover the cost of replacing the product and it's installation.*

* See our website for full terms and conditions www.connectedswitchgear.com.au

IMPACT