



IMPACT Series

IP66 Industrial Range RCD Protected Outlets



Data Specification **2024**



AUSTRALIA WIDE DELIVERY
Expedited delivery to all states in Australia



SAME DAY DISPATCH
Orders prior to 12PM will be dispatched the same day



5 YEAR WARRANTY
You can get a trusted 5 Year In House Warranty with CSG

[DESCRIPTION]

In applications that require protection of life, the IMPACT S Series range of socket outlets have inbuilt RCD protection. The RCD works by constantly monitoring and comparing the current flow in both the active and the neutral circuits of an electrical installation. The IMPACT S Series combination switched socket outlets have the optional LED phase indicator and panel ID label panel for circuit identification. Manufactured from impact resistant material ensures that it will withstand harsh treatment in most industrial environments.

[FEATURES]

- Impact Resistant
- Automatic Snap Catch Latch
- Silicone Based Seals
- Soft Feel Rotary Switch
- Hose Proof & Dust Resistant Flaps
- Ample Conduit Entries
- Optional LED Phase Indicator
- Optional ID Label Kit

[TECHNICAL PARAMETERS]

- Rated Voltage: 250V/500V AC
- Rated Frequency: 50/60Hz
- Operating Temp: -40°C - 80°C
- IP Protection: IP66
- 10000kA 30mA Rating
- Complies with Standard
AS/NZS 3100:2017+A1
AS/NZS 3112:2017
AS/NZS 61008.1:2015

[APPROVALS]

SAA Approved

[IMAGES]



RPCS310-S



RPSO532-S

[SPECIFICATIONS]

Product Code	Rating (Amps)	Voltage (V)	No. Of Pins	Configuration	Conduit Entries
RPCS310-S	10A	250V	3	Flat Pin	2 x 25mm, 2 x 32mm
RPCS315-S	15A	250V	3	Flat Pin	2 x 25mm, 2 x 32mm
RPCS510-S	10A	500V	5	Round Pin	2 x 25mm, 2 x 32mm
RPCS520-S	20A	500V	5	Round Pin	4 x 25mm
RPCS532-S	32A	500V	5	Round Pin	2 x 25mm, 2 x 32mm
RPSO310-S	10A	250V	3	Flat Pin	4 x 25mm
RPSO315-S	15A	250V	3	Flat Pin	4 x 25mm
RPSO510-S	10A	500V	5	Round Pin	4 x 25mm
RPSO520-S	20A	500V	5	Round Pin	4 x 25mm
RPSO532-S	32A	500V	5	Round Pin	4 x 25mm

[WIRING DIAGRAM]

3 Phase Connection - Without Neutral

NOTE: RCD's will function even without a neutral supply or load. However, when installing an RCD to a circuit without the supply of a neutral connection, for the test button to operate correctly, the connection of a bridging resistor (R2.4W not supplied) between the load side neutral terminal and load side phase terminal 2 or 4 is required. Failure to include a bridging resistor in these installations may result in damage to the test circuit.

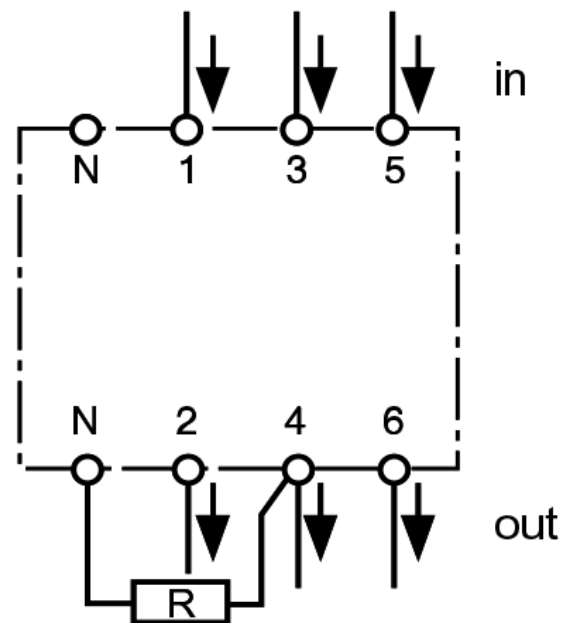

[WARRANTY]

Connected Switchgear IMPACT S series of product come with a trusted 5 Year In House Warranty. That means that you have peace of mind knowing that if a fault develops within a five year period, Connected Group Australia will cover the cost of replacing the product and it's installation.*

* See our website for full terms and conditions www.connectedswitchgear.com.au