

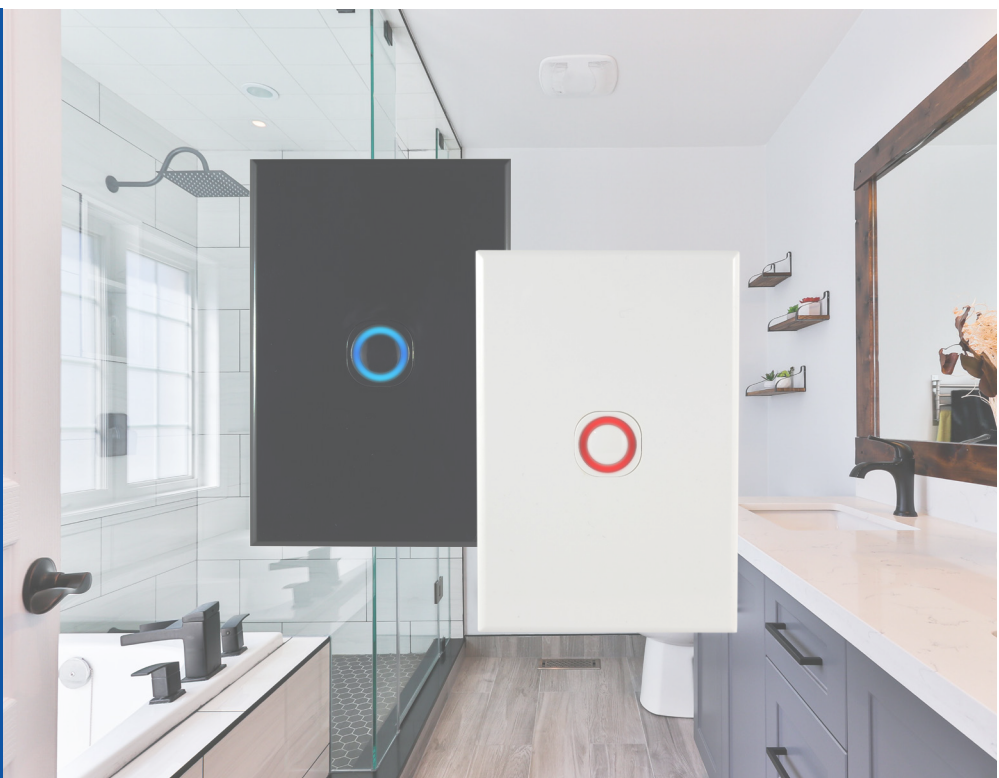

GEO SERIES

Electronic Time Delay Switch

Data Specification **2024**



AUSTRALIA WIDE DELIVERY
Expedited delivery to all states in Australia



SAME DAY DISPATCH
Orders prior to 12PM will be dispatched the same day



5 YEAR WARRANTY
You can get a trusted 5 Year In House Warranty with CSG

[DESCRIPTION]

CSG's electronic time delay switch is the first electronic time delay switch that can be installed in both 2 and 3 wire configurations. A total of 8 pre-defined 'time out' times ranging from 30 seconds to 480 minutes can be easily selected by simply removing the front cover plate and selecting the corresponding toggles. Three function modes are available: repeat time out, turn off and run on timer. Available with either red or blue LED indicators and in both black and white plate colour. Whilst electronic switching devices are highly susceptible to inrush currents caused by capacitive and inductive loads, CSG is the first company to integrate current over protection circuitry in our time delay switch.

[FEATURES]

- Slimline 6.5mm Thick
- Both 2 and 3 Wire Applications
- Time Out Range 30 seconds - 480 minutes
- Overcurrent Protection Circuitry
- 3 Program Modes: Time Out, Turn Off, Run On Timer
- Blue or Red LED Indicator
- Plates in White & Black

[APPROVALS]

SAA Approved

[IMAGES]

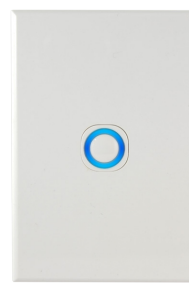

LSTDE-L



LSTDER-L



LSTDEB-L



LSTDERB-L

[TECHNICAL PARAMETERS]

Connection Type:	2 Wire with Optional 3 Wire
Supply Voltage:	240Vac +/-10%
Rated Frequency:	50Hz
Contact Status:	Normally Open
Max Current:	10amp
Over Temp Cutout Current:	12amp
Max Load:	2400W (Incandescent) 2400WA (Fluorescent)
Min Load:	10W (when no neutral terminal)
Operating Temperature:	0 to 50 °C
Cycle Timer Range:	30 secs - 480 minutes
Factory Setting:	30 secs
Complies with:	AS/NZS 60669.2

FUNCTION:

CSG's electronic time delay can be set to 1 to 3 different program types:

TYPE A - Start/Restart

Time out period selected will commence countdown when the button is pressed. In the event that the button is pressed again prior to the preset time out, the program will recommence timing again.

TYPE B - Start/Stop

Time out period selected will commence countdown when the button has is pressed from the 'OFF' position. Once the programmed timing is running and the button is pressed again, the programmed timing will stop and power off the switch.

TYPE C - Start/Run On/Stop

This function can only be performed when the Type C Wiring Diagram is installed (Refer to Fig 4) and the Program Type (bit4) is set to B. In this setting, the device performs a run on timer function. Pressing the button once turns the load on for a maximum of two hours or until the button is pressed a second time. Pressing the button a second time commences the configured run on timer countdown setting. Pressing the button a third time overrides the run on timer countdown and turns the load off.

Note: Additional switching points cannot be used with Type C operation.

Setting Program Type:



Bit 4	Program Type
A	Type A
B	Type B
B	Type C (Refer to Fig. 4)

LED Indications:

TYPE	Indication
Dimmed Solid	Off
Solid Single Flash	Time Out Period Countdown
Solid Double Flash	Run On Timer Countdown
Continuous Flash	Off - Over Temperature Fault

Setting Program Type:

Bit1	Bit2	Bit3	Time
0	0	0	30s
1	0	0	1m
0	1	0	5m
1	1	0	10m
0	0	1	30m
1	0	1	60m
0	1	1	120m
1	1	1	480m

Notes for Installation:

- As with all devices that do not have a neutral connection, for the unit to operate, a working load must be connected and a current passed through the load even when off. In various applications, a load correction device may be required. For instance, inductive, fluorescent, compact fluorescent and LED loads less than 10W may require a load correction device such as the CSG (MLCD) wired across the load to provide power to the circuit in the OFF state (refer to Fig. 1). Luminaries with power factor correction capacitor do not need an additional load correctional device.
- When no neutral connection is provided, fluorescent light loads are restricted to electronic type ballasts, and low voltage transformers are restricted to electronic type only.
- In installations where additional switching points requires the installation of a momentary press mechanism connected to the 'CONT' terminal (refer to Fig. 2). **Note:** When using the Optional Control Switch, a momentary press mechanism must be used.
- The maximum recommended length of the control wire to remote push buttons is 50m.
- Optional wiring diagram for applications where connected loads require a higher current rating than the rated 10A using an external 240V AC auxiliary contact (Refer to Fig. 3)

[WIRING DIAGRAMS]

LOW WATTAGE 2 WIRE
FIG. 1

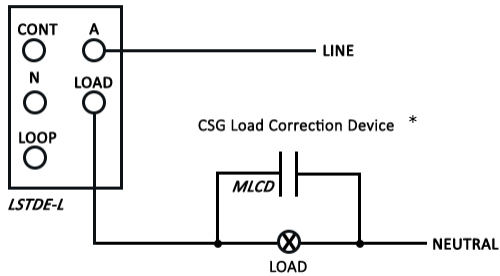

*Available from Connected Switchgear (MLCD)

ADDITIONAL SWITCHING POINTS
FIG. 2

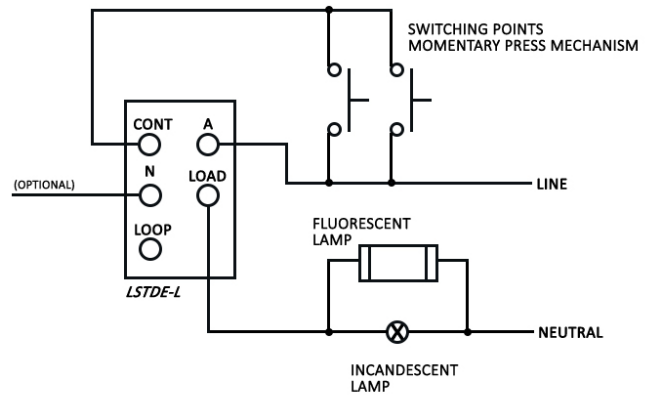

HIGH CURRENT

FIG. 3 Note: A neutral connection to the switch is required to operate auxiliary contactors. Switch will not operate correctly in 2 wire mode.

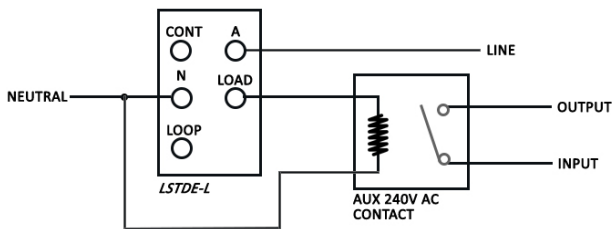

TYPE C START / RUN ON / STOP
FIG. 4

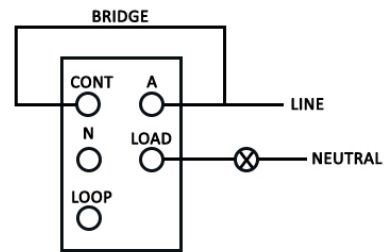

LOW WATTAGE 3 WIRE
FIG. 5

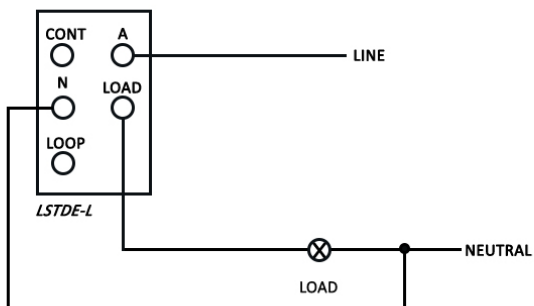

[RELATED PRODUCTS]



MLCD

[WARRANTY]

Connected Switchgear products come with a trust 5 Year In House Warranty. That means that you have peace of mind knowing that if a fault develops within a five year period, Connected Group Australia will cover the cost of replacing the product and it's installation.*

WARNING: Warranty will be voided unless a surge protection device is placed in the input side of the time delay switch.

* See our website for full terms and conditions www.connectedswitchgear.com.au