

## Socket Outlet Pendant SP310, SP315



### Specifications

Connection type	Double Pole
Supply voltage	230-240V ac +/-10%
Frequency	50Hz
Max current	10amp, 15amp
Size of Flexible Cord	10A(1.5mm <sup>2</sup> ) 15A(2.5mm <sup>2</sup> )
Compliance	AS/NZS 3120 AS/NZS 3112
Approval	SAA
Required Compliance Mark	5453

### Features and Applications:

The Connected Switchgear Socket Pendant Outlet is designed for use in industrial applications where access to power should be suspended over head. The casing of the SP series product is made from high quality impact and chemical resistant material to give superior performance and protection in industrial applications.

Switching of power to the outlet is double pole in accordance with AS/NZS 3120.

Available in both 10 and 15amp.

### Wiring Instructions:

1. Strip the insulation as pictured (Figure 2)
2. Connect the earth wire (Green & Yellow) to the terminal marked "⏏" or "E" (Figure 1)
3. Connect the neutral wire to switch terminal "A1" (Figure 1)
4. Connected switch terminal wire "L1" to socket outlet "N" (Figure 1)
5. Connect the active wire to switch terminal "A2" (Figure 1)
6. Connect switch terminal wire "L2" to socket outlet "A" (Figure 1)
7. Tighten cord clamp around the outer sheath of the cable and check the wires are in the correct position and the terminal screws are fully tightened
8. Insert the pan assembly inside the outer housing, tighten the screws and screw gland tight

### Wiring Diagram:

Figure 1.

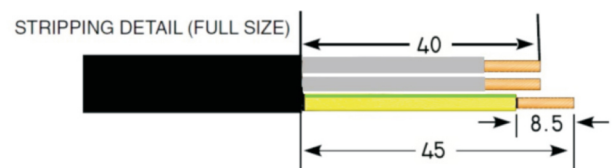
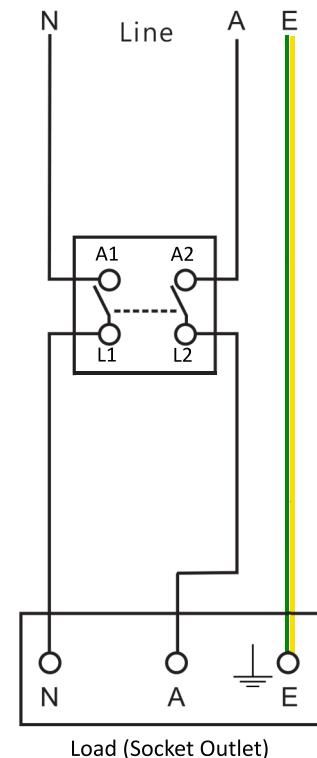

Figure 2.