



I-TOUCH[®] SERIES

Home Automation

Data Specification **2024**



AUSTRALIA WIDE DELIVERY
Expedited delivery to all states in Australia



SAME DAY DISPATCH
Orders prior to 12PM will be dispatched the same day



10 YEAR WARRANTY
You can get a trusted 10 Year In House Warranty with CSG

[DESCRIPTION]

The Connected Switchgear I-TOUCH® Series is a collection of touch controlled glass switch panels designed for residential and commercial use. The range includes socket outlets, wall switches and smart dimmers in a variety of configurations. Each product includes an extensive feature set including the option of controlling a remote relay of 30amp and the remote control button in another panel via a wired interface.

Smart dimmers can be used to control a wide variety of loads including capacitive and inductive loads by using auto load detection circuitry.

Whilst the products can be used standalone, in order to benefit from the full feature set, wireless group control functionality has been incorporated into its design that allows button groups of up to 16 buttons to be controlled using a single button in up to 33 panels. When installing the products in conjunction with the I-TOUCH® Series gateway interface, up to 128 panels can be controlled by any smart device and anywhere around the world with an Internet connection.

[FEATURES]

- Glass Plates
- LED Multi-Coloured Indicators
- Touch Responsive Buttons
- Child Lock Function
- 4 Button Modes: Normal, Light Sensing on/off, Light Sensing on/timer off, Timer Off
- Circuit Lock Mode
- Day of Week Timers
- Do Not Disturb Mode
- Overcurrent Protection
- Over-Temperature Protection

[APPROVALS]

SAA Approved

[TECHNICAL PARAMETERS]

POWER OUTLETS

- Rated Voltage: 240V AC
- Rated Frequency: 50/60Hz
- Amperage: 10A per channel
- Complies with:
AS/NZS 3112:2017+A1
AS/NZS 3100:2017+A1-3

LIGHT SWITCHES AND DIMMERS

- Rated Voltage: 240V AC
- Rated Frequency: 50Hz
- Amperage Switches:
1-4 Gang: 10A per channel
5-6 Gang: 5A per channel
- Amperage Dimmers:
480VA per channel
- Complies with
AS/NZS 60669.1:2020
AS 60669.2.1:2020

[TECHNICAL SPECIFICATIONS]

WIRELESS COMMUNICATION

MiWi™ Wireless Networking Protocol

Networking Protocol

Multi-hop Mesh Topology

Networking 2.4GHz, IEEE Std

802.11b™ RF Transceiver Modules

Data Encryption using XTEA

Block cipher with 32bit block size, 64bit key length

Scalability 128 Panels per gateway connection

4G ACCESS

Unique WiFi connection priority

Mobile Access Backup 4G cloud based hosting services when local WiFi not detected

Secure socket connection SSL

[IMAGES]

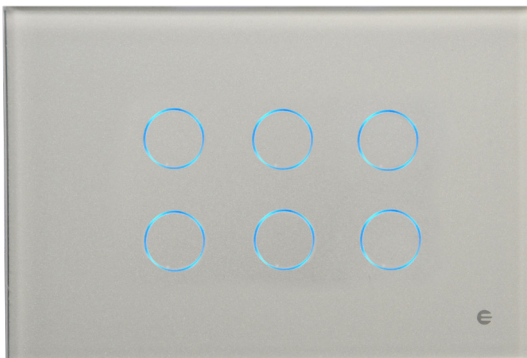

T-LS056RF

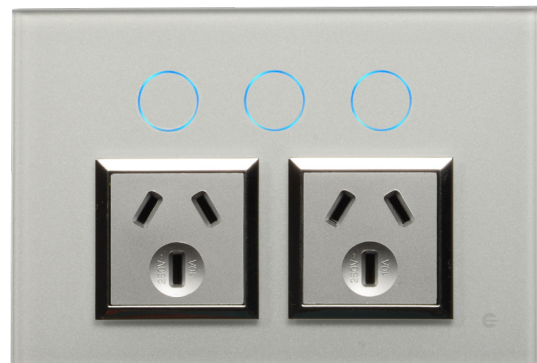

T-POD10XRF



T-LS022DMRF



T-POS10RF

[FEATURE SET]

AUTO ON/OFF

Timer ON/OFF	Set button timers to activate auto switching on and auto switching off
Days of Week Timers	Button timers can be set to any or every day of the week
Global Timers	Global timers feature allows a button timer to be included in a global group that enables the group to be activated or deactivated with one button touch

BUTTON FUNCTIONS

Button Mode	Each button can be set to 1 to 4 available button modes: Normal, Light sensing on/off, Light sensing on/timer off, or Timer off
Dual Button	Buttons have both a single and double tap function allowing isolated switching and group control of any other button within the WiFi network
Scene Command	Up to 16 buttons can be linked to any one button within the WiFi network
Global Commands	Any button can be set to perform a system-wide global command such as trigger a Home, Away, Goodnight or Good Morning command. In addition, the mobile app has a GPS positioning feature that allows these commands to be triggered by the relative position of the user in relation to the installation, such as leaving or arriving home
Child Safety Lock	Prevents unwanted button operation
Do Not Disturb	Lock out of button operation during set times
Auto Dimming	LED indicators automatically adjust in brightness to room light level ensuring they are never too dim or too bright
Multi-Coloured	LED indicators are multi-coloured indicating different functions, button state or warnings

[FEATURE SET]

ENERGY SAVING

Time Out Time Out feature allows the button to automatically switch off after a user defined period is set

System Health Check Real-time system monitoring to any system malfunctions

SAFETY CONTROL

Over Current Shutdown Shuts down panel from operation if an overcurrent situation is detected

Over Temperature Sensor Shuts down panel from operation if an over temperature situation is detected

ACCESS YOUR HOME REMOTELY - ANYWHERE, ANYTIME

If you want to control your smart home from anywhere, anytime, then the I-TOUCH® gateway allows you to access the I-TOUCH® systems with the reliability and speed using the I-TOUCH® mobile app on your smart phone or tablet.

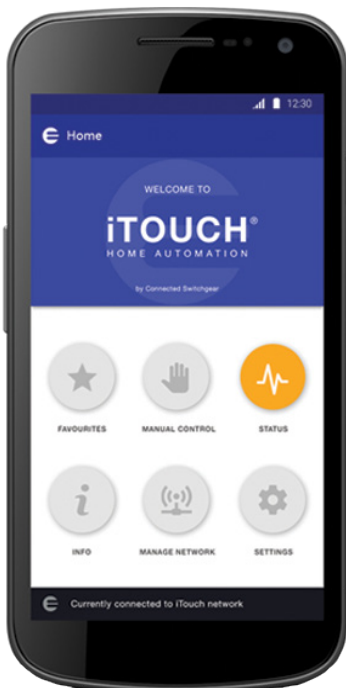

Scan the QR Code to watch the I-TOUCH® video



I-TOUCH®

[WHAT SETS I-TOUCH® APART]

RELIABILITY OF SERVICE

Most proprietary systems require interface through an internet connection via a cloud based MQTT broker. However, poor internet connection or “lost messages” often results in system commands not being completed causing frustration and noticeable delays in switching. I-TOUCH® approach is unique in that it relies primarily on a devices connection to your local WiFi network as the means of interfacing with the system and only when a local WiFi connection is not detected does it switch to 4G cloud based service. The result is immediate and reliable switching.

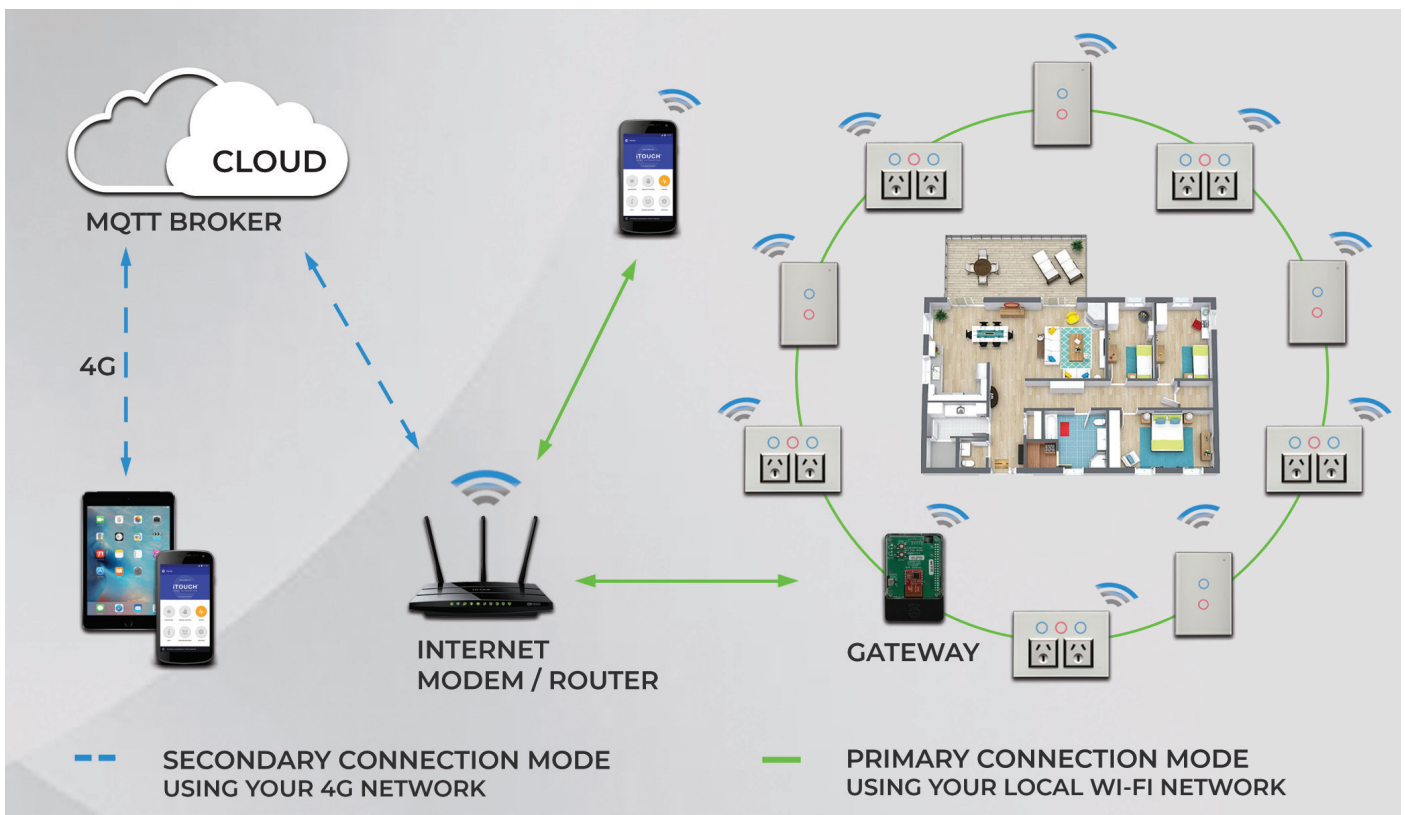

[WHY CHOOSE I-TOUCH®]

The first glass plate, multi coloured LED indicator series including power outlets that seamlessly integrates automation. I-TOUCH® products are designed to operate individually if required or as a local network when programmed. Give your home a modern look and feel combined with clever control.

EASY TO OPERATE

The I-TOUCH® Series of products offer an extensive but simple to use feature set that when utilised can offer the convenience of taking care of most processes you would normally perform manually throughout the day. Program lights to come on when required or switch off when not. Turn all the lights off with the touch of a button when you leave home or turn in for the night. Create different scenes for effects. It's clever, intuitive and reliable.

AFFORDABLE COMPARED TO OTHER SYSTEMS

The I-TOUCH® range of products offers an extensive feature set that can be adapted to every lifestyle. Total cost depends on the number of panels required. Whilst some home automation systems may appear as a cheaper alternative, when factoring in specialist wiring or a central controlling hub, limitations in control, flexibility, or features, I-TOUCH® stands out as a serious contender for value.

BENEFITS OF INSTALLING I-TOUCH®

I-TOUCH® products do not restrict the number of or types of globes installed like many other Bluetooth or WiFi products do. As long as the total current does not exceed the rating of the product, you can choose any globe you wish. Additionally, the I-TOUCH® smart series dimmers have auto load detection that can detect the kind of load being light or fan load and adjust the circuitry accordingly to allow both light and fan speed control.

EASY INSTALLATION

Unlike other home automation systems, I-TOUCH® does not require specialist wiring, central bus or installation processes. Wall switches operate using switched active and a neutral connection and socket outlets require a standard active, neutral and earth. Each panel has the ability to operate independently of others and does not require a central hub to control its processes, allowing retrofitting into existing homes.

STYLE MEETS CLEVER EFFICIENCY

The I-TOUCH® range of switches and power outlets connect via WiFi. They set a new standard for modern living with its aesthetic appeal, usability and enhanced functionality.

I-TOUCH®

[SPECIFICATIONS]

POWER OUTLETS

Product Code	Type	Current Rating Per Circuit
T-POS10RF	1 Gang Power Outlet	10A
T-POS10XRF	1 Gang Power Outlet + 1 Button	10A
T-POD10RF	2 Gang Power Outlet	10A
T-POD10XRF	2 Gang Power Outlet + 1 Button	10A

SMART DIMMERS

Product Code	Type	Current Rating Per Circuit
T-LS021DMRF	1 Channel Dimmer	480VA/Per Channel
T-LS022DMRF	2 Channel Dimmer	480VA/Per Channel
T-LS023DMRF	3 Channel Dimmer	480VA/Per Channel

WALL SWITCHES

Product Code	Type	Current Rating Per Circuit
T-LS101RF	1 Way Wall Switch	10A
T-LS102RF	2 Way Wall Switch	10A
T-LS103RF	3 Way Wall Switch	10A
T-LS104RF	4 Way Wall Switch	10A
T-LS055RF	5 Way Wall Switch	5A
T-LS056RF	6 Way Wall Switch	5A

ACCESSORIES

Product Code	Type	Current Rating Per Circuit
T-R30	Remote Relay	30A
T-GW012_RF	Gateway Interface	-



T-GW012_RF



T-R30

[WIRING DIAGRAM]

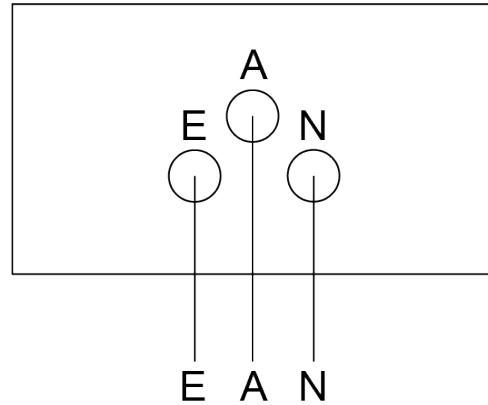

Wiring Diagram
for GPO

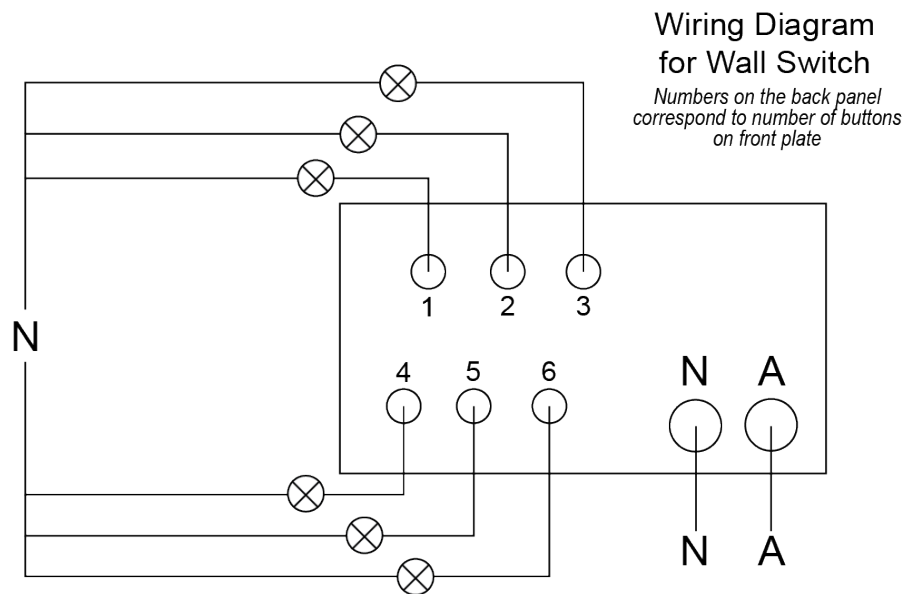

Wiring Diagram
for Wall Switch

*Numbers on the back panel
correspond to number of buttons
on front plate*

[INSTALLATION NOTES]

WARNING - PLEASE READ THIS DOCUMENT PRIOR TO INSTALLING

iTOUCH® Home Automation devices are electronic products and as such require more than usual installation care. To ensure warranty is not voided, please take care during installation of the following:

1. When connecting loads (wiring accessories or luminaires) to any panel except dimmer panels, it is imperative that the total load requirement of the connected devices does not exceed the rating of the panel. Failure to follow this directive may result in product failure and void warranty.

[INSTALLATION NOTES CONT.]

If capacitive or inductive loads are connected, and in the event that the power requirement of the load is not indicated on the product packaging, you should contact the manufacturer for specific information that relates to the total power requirement of the device and ensure this value rating does not exceed the rating of the panel.

Please note that many LED globes with an advertised rating of 7-10W can have as high as 100amps of inrush current, which is not advertised on the product packaging

In instances where the total power requirement exceeds the panel rating, you may have options that safely connect the device to the iTOUCH® panel such as installing a current limiting device or larger relay switching device between the iTOUCH® panel and the load connected.

2. BEFORE connecting power to the iTOUCH® products, it is imperative that you have installed surge arrestors in the electrical system before the wired circuits of iTOUCH® products to ensure the products are not affected by voltage surges. Each incoming and phase and neutral will require a surge arrestor device.
3. NEVER connect an iTOUCH® panel to live power. Ensure all wiring connections are terminated PRIOR to making electrical circuits live.
4. Ensure that the products as installed are not being exposed to building dust or debris from the buildings wall construction.
5. Do not overtighten the panels to the wall surface. This can lead to plate distortion if the wall surface is not flat and can result in poor contact between the glass plate cover and the silicone button pads. This will result in loss of button sensitivity.
6. Ensure that the panels are not installed further than 9 metres apart.
7. After installation of the glass plates, the panel will calibrate its touch sensitivity. During this initial calibration, it is possible for the buttons to enter locked mode. If so, when the button is touched it will flash white 3 times.

[INSTALLATION NOTES CONT.]

To unlock, touch and hold a button for 10 seconds. After 5 seconds the button will flash blue 3 times. Continue to hold until the button flashes green 3 times, indicating the button is now enabled.

To lock a button, simply reverse the above procedure. After 10 seconds the button will flash blue 3 times.

[WARRANTY]

Connected Switchgear I-TOUCH® products come with a trusted 5 Year In House Warranty. That means that you have peace of mind knowing that if a fault develops within a five year period, Connected Group Australia will cover the cost of replacing the product and it's installation.* For full installation instructions, please view the full Technical Manual available upon request.

* See our website for full terms and conditions www.connectedswitchgear.com.au